

bili•hut™ Instructions for Use

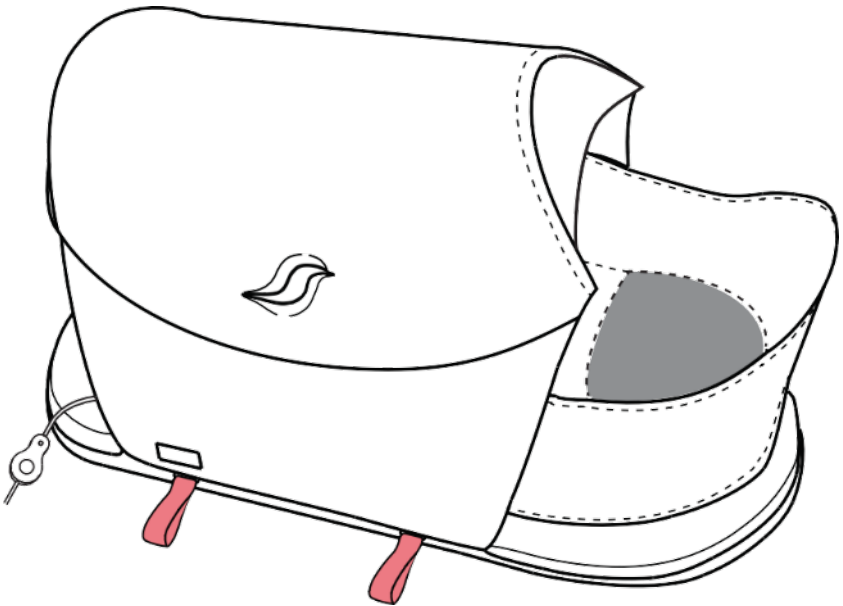

Little Sparrows
Technologies
Big ideas for little babies

CAUTION



U.S. federal law restricts this device to sale by or on the order of a physician or properly licensed practitioner.

Copyright © February 2024

Little Sparrows Technologies, Inc.
70 Tower Office Park
Woburn, MA 01801
(781) 725-2460

bili•hut™ is a trademark of Little Sparrows Technologies.

Doc # BH-IFU-001
Ver. 4, CO-159

Product Responsibility

The **bili•hut™** was designed by Little Sparrows Technologies. This manual provides information on how to assemble, operate, disassemble, clean, and store the **bili•hut™**. Follow all instructional materials and labels provided with the **bili•hut™**. Check this device regularly for defects. NEVER use a **bili•hut™** or any **bili•hut™** components that appear to be defective.











DO NOT make changes to the **bili•hut™**. DO NOT alter the **bili•hut™**. Changes to the **bili•hut™** should only be made by a trained Little Sparrows Technologies representative. Damage to this device due to improper use is solely the responsibility of the user. Little Sparrows Technologies is not responsible for damage from the user making repairs or taking any action not stated in this manual, **bili•hut™** labels, or other instructional materials prepared by Little Sparrows Technologies.

See **Section 5** for instructions on troubleshooting problems with the **bili•hut™**.

Table of Contents

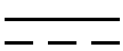
Product Responsibility.....	i
Table of Contents.....	ii
Label Symbols Key.....	iii
Section 1: Overview.....	1
1.1 Instructions on the Use of this Manual.....	1
1.2 Intended Use.....	1
1.3 Components.....	2
1.4 Accessories.....	11
Section 2: Safety.....	16
2.1 Indications for Use.....	16
2.2 Contraindications.....	16
2.3 Recommendations.....	16
2.4 General Warnings.....	17
2.5 General Cautions.....	20
Section 3: Using the bili•hut™.....	21
3.1 Assembling and Setting-up the bili•hut™.....	21
3.2 Operating the bili•hut™.....	25
3.3 Removing the Patient from the bili•hut™.....	30
3.4 Actions for an Environment High Temperature Warning.....	32
3.5 Disassembly.....	34
Section 4: Maintenance.....	36
4.1 Cleaning.....	36
4.2 Disposal.....	39
Section 5: Troubleshooting.....	41
Section 6: Contact and Reorder Information.....	45
Section 7: Specifications.....	46
7.1 Electrical	47
7.2 shell	48
7.3 base	48
7.4 base mattress	48
7.5 nest frame	48
7.6 Fully disposable nest mattress	49
7.7 Fully disposable nest	49
7.8 disposable nest mattress	49
7.9 disposable nest liner	49
7.10 perch	49
7.11 bili•hut™ (assembled).....	50
7.12 Environmental.....	51
7.13 WEEE Statement.....	52
7.14 Spectral Irradiance.....	53
Appendix A.....	57
Index.....	59

Label Symbols Key

Symbol	Meaning
	<p>Cautions draw your attention to any hazards that could damage the device or could result in severe but reversible injury to the patient and/or user.</p> <p>Warnings describe serious adverse reactions and potential safety hazards, limitations in use imposed by them, and steps that should be taken if they occur.</p>
	Single use
	Consult instructions for use
	Eye protection
	IEC Type BF applied part
	IEC Class II equipment
	Direct current
IP23	Protected against solid objects over 12mm Protected against direct sprays of water up to 60 degrees from the vertical
R_x Only	CAUTION: Federal law restricts this device to sale by or on the order of a physician.
	Temperature limit
	Manufacturer
	Waste Electrical and Electronic Equipment (WEEE)

Section 1: Overview

1.1 Instructions on the Use of this Manual

This manual contains instructions on the proper use and maintenance of the **bili•hut™** and its components to be followed by a healthcare professional. This device should only be used by properly trained and documented caregivers who have read and thoroughly understand the entire contents of this manual. They should also know the risks and benefits of infant phototherapy and use of the device. Use of a **bili•hut™** by an unfit or untrained caregiver may result in injury to the patient or user. Pay strict attention to all safety warnings and cautions. Refer to the **Product Responsibility** section of this manual for specific responsibilities associated with the use of this product.

DO NOT lose or dispose of this manual. For supplemental information, contact Little Sparrows Technologies using the contact information in **Section 6**.

1.2 Intended Use

The intended use of the **bili•hut™** is for the treatment of neonatal hyperbilirubinemia.

Use the **bili•hut™** only as prescribed by a physician or properly licensed practitioner. Other uses of the **bili•hut™** may result in overtreatment or undertreatment of the patient.

The **bili•hut™** is not intended to prevent the onset of jaundice.

1.3 Components

NOTE: Only use the components provided by Little Sparrows Technologies shown in this section with the **bili•hut™**.

The diagrams on this page and the next page show the location of all standard **bili•hut™** components.

Assembled bili•hut™
base
base mattress
shell
perch (optional accessory: available for use with some bassinet stands) See section 1.4 for details.
Power supply

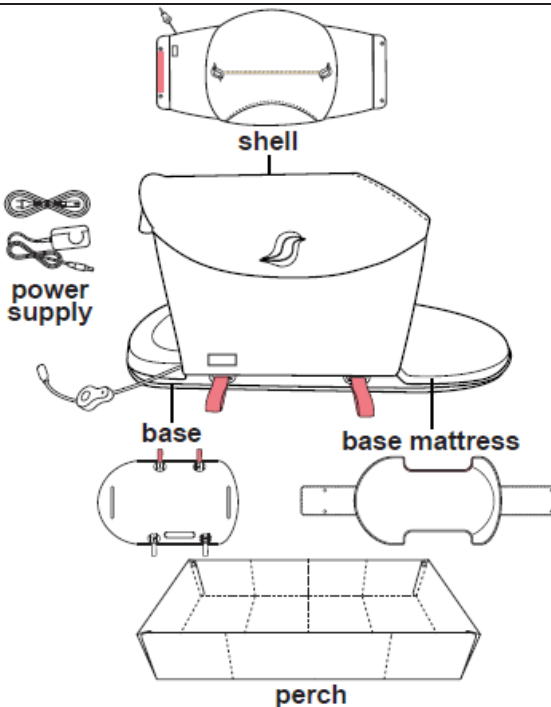

fully disposable nest components
fully disposable nest
fully disposable nest mattress

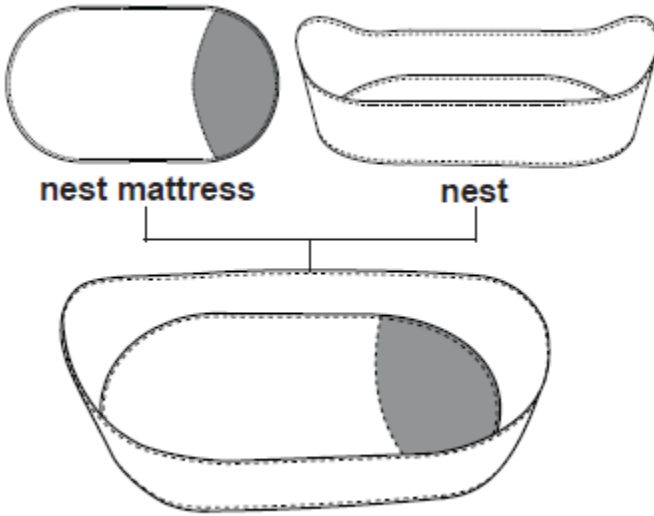

These components come with the standard package.

1.3.1 base and base mattress

The **base** maintains the structure of the **shell** during treatment.

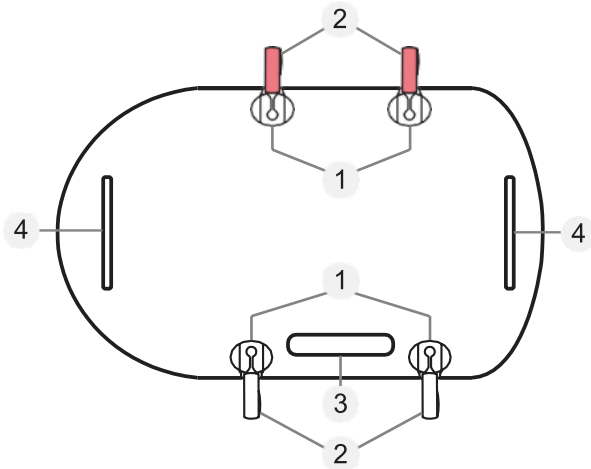

Feature #	Description
1	Magnetic clasps on the base attach to the shell clasps for assembly.
2	Red and gray straps signal proper assembly of the shell and allow easy disassembly.
3	Handle enables surface-free assembly of the shell .
4	Slots in the base allow easy attachment of the base mattress .

The **base mattress** cushions and aligns the treatment area.

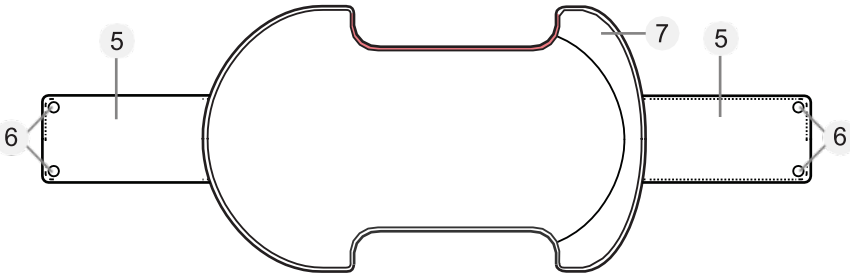

Feature #	Description
5	Straps slide through slots in the base to attach the base to the base mattress .
6	Snaps attach the straps to secure the base to the base mattress .
7	The bumper helps properly align the nest for treatment.

1.3.2 shell

The **shell** provides high-intensity phototherapy treatment with blue LED treatment lights.

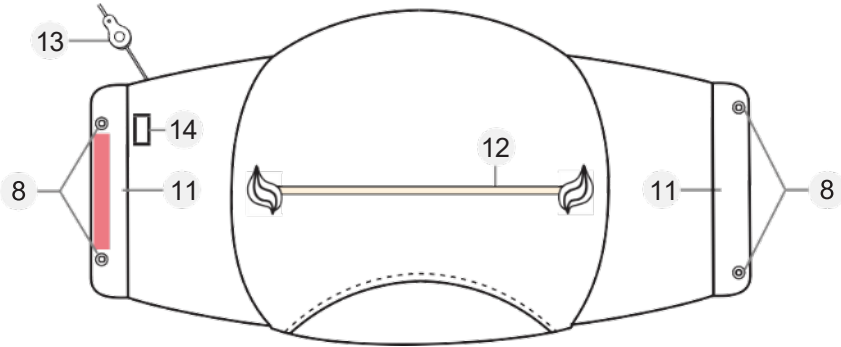

Shell exterior

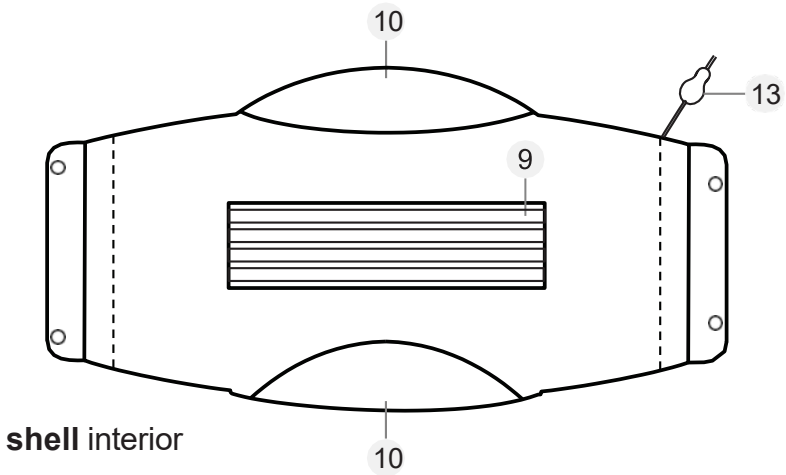

shell interior

Feature #	Description
8	Magnetic clasps on the shell pair with the base clasps for secure attachment.
9	Blue LED (Light Emitting Diode) treatment lights form the light array to administer high-intensity phototherapy to the patient.
10	Back and front flaps focus light on the treatment area. The flaps also shield the area around the bili•hut™ so that only a small amount of blue light will be seen by the user.
11	Red and gray flaps used to indicate proper shell orientation in complete assembly of the bili•hut™ .
12	The yellow indicator light alerts the user to an Environment High Temperature Warning. See Section 3.4 of this manual for more information. The yellow indicator light is not visible unless the bili•hut™ is used in a too-hot environment.
13	The power cord connects the assembled bili•hut™ to a safe power supply . After the power supply is plugged in to a safe and active outlet, the power switch controls whether the bili•hut™ is “ON” or “OFF”. A small blue indicator light on the power switch illuminates when the power cord is plugged in and the power switch is in the “ON” position.
14	The timer tracks the total use of the blue LED treatment lights in hours. The timer does NOT track individual patient treatment times. The timer has a max reading of 99,999.9 hours.

1.3.3 fully disposable nest



The **fully disposable nest** is used without the nest frame or liner.

The **fully disposable nest** is disposable when soiled and is for single patient use. Please see the contact information in **Section 6** of this manual to order additional **nests**.

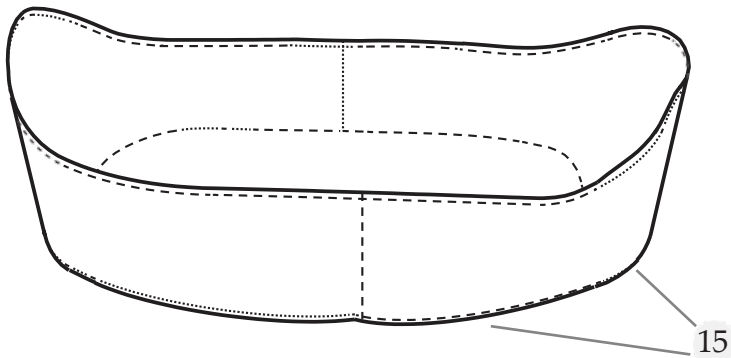

Feature #	Description
15	The fully disposable nest is made of soft disposable materials and minimizes light leakage.

1.3.4 fully disposable nest mattress



The **nest mattress** provides cushioning for the patient and uses color-blocking to guide patient placement. The **nest mattress** is disposable when soiled and is for single patient use. Please see **Section 6** of this manual to order additional **nest mattresses**.

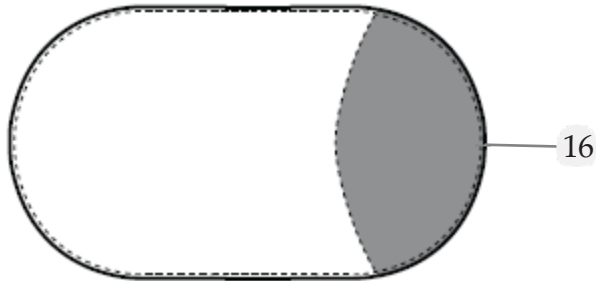

Feature #	Description
16	The dark section of the nest mattress guides proper patient placement within the nest. Specifically, the patient's head and neck are placed entirely within the dark section of the nest mattress.

1.3.5 power supply

The medical-grade **power supply** attaches the **bili•hut™** power cord on the **shell** (see **Feature #13** of **Section 1.3.2**) to a safe and active electrical outlet. The **power supply** is composed of the power brick and AC cord.

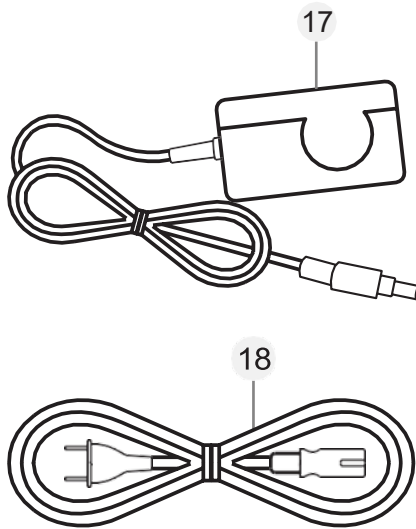

Feature #	Description
17	Power brick connects to the bili•hut™ power cord and the AC cord.
18	AC cord connects the power brick to a safe and active electrical outlet.

1.4 Accessories

NOTE: Only use the components provided by Little Sparrows Technologies shown in this section with the **bili•hut™**.

These components may be purchased in addition to the components that come in the standard **bili•hut™** package on the Little Sparrows Technologies website:
www.littlesparrowstech.com

nest liner components
nest frame
disposable nest liner
disposable nest liner mattress

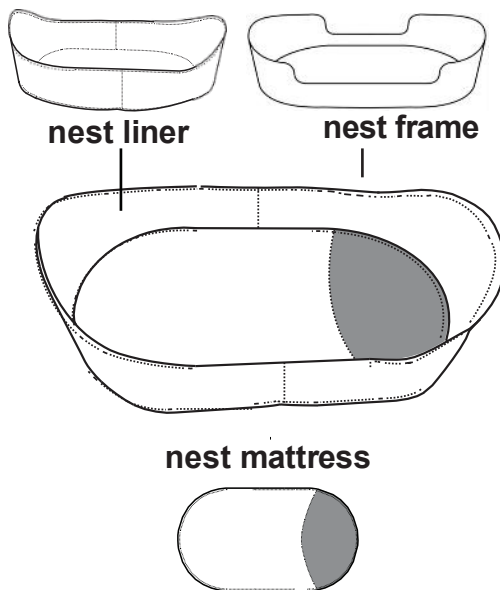

1.4.1 nest frame

The **nest frame** properly positions the patient for treatment.

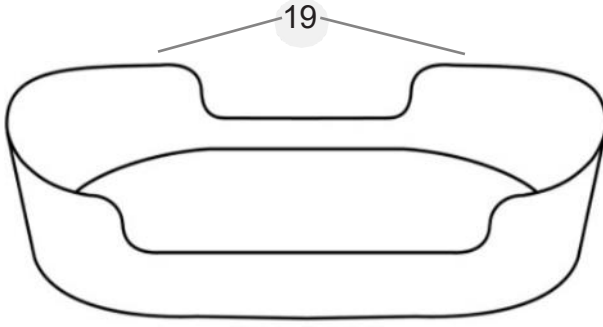

Feature #	Description
19	The raised ends help support the nest frame to minimize light leakage and hold in warmth.

1.4.2 disposable nest liner



The **disposable nest liner** improves light array efficacy and maintains cleanliness of the **nest frame**. The **disposable nest liner is** disposable when soiled and is for single patient use. Please see the contact information in **Section 6** of this manual to order additional **disposable nest liner**.

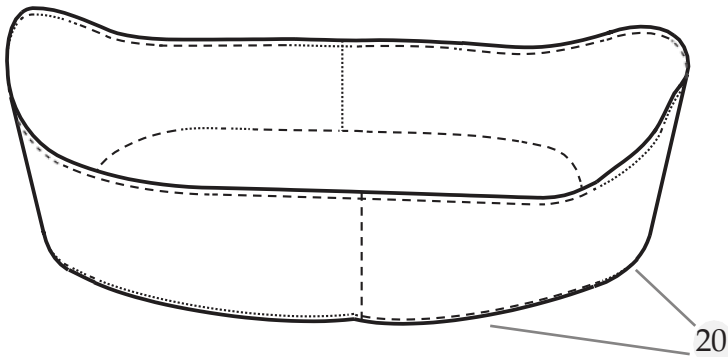

Feature #	Description
20	The disposable nest liner easily slips over nest frame using a bottom opening in the liner's fabric.

1.4.3 disposable nest liner mattress



The **disposable nest liner mattress** provides cushioning for the patient during use.

The **disposable nest liner mattress** is disposable at the end of treatment; a new **disposable nest liner mattress** is used for the next patient. Please see **Section 6** of this manual to order additional **disposable nest liner mattresses**.

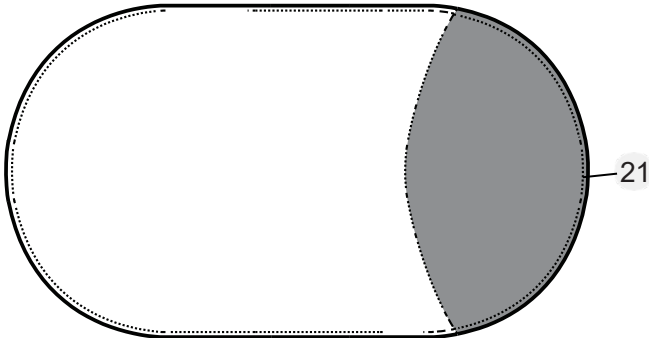

Feature #	Description
21	The dark section of the nest mattress guides proper patient placement within the nest. Specifically, the patient's head and neck are placed entirely within the dark section of the nest mattress.

1.4.4 perch

The **perch** is an optional accessory to the **bili•hut™** that converts most hospital-grade bassinet stands into a safe, flat surface on which to use the **bili•hut™**. The dimensions of the assembled **perch** are 28.5 x 15 x 5.5 inches (or 72.5 x 38 x 13.5 cm). Please refer to manufacturer dimensions of the bassinet stand to determine if the **perch** is appropriate for use.

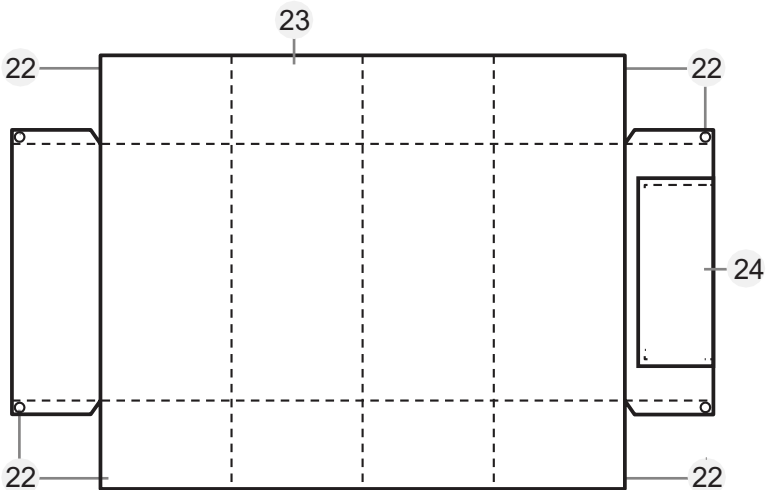

Feature #	Description
22	Snaps maintain the shape of the perch during use.
23	Panels ease disassembly and storage of the perch .
24	Mesh pouch holds power supply during use.

Section 2: Safety

2.1 Indications for Use

The **bili•hut™** provides phototherapy for the treatment of neonatal hyperbilirubinemia, commonly known as neonatal jaundice, during the newborn period in the clinical or home setting.

2.2 Contraindications

Contraindications are conditions when the **bili•hut™** should not be used because the risks outweigh the benefits of using it.

The **bili•hut™** is contraindicated for use with a patient who is in an incubator or under a radiant warmer. This is because the **bili•hut™** was not designed to be used with these other medical devices.

2.3 Recommendations

Little Sparrows Technologies recommends that the **bili•hut™** be used for patients with a birthweight of more than 2500 grams (5.5 pounds) and with a gestational age of greater than or equal to 35 weeks. However, the prescribing clinician defines the need for phototherapy with each patient.

Use the **bili•hut™** in these environments:



- recommended room temperature: select a location where the room temperature can be maintained between 70°F and 76°F (21.1° C and 24.4°C) for the patient's comfort and safety during treatment
- humidity range: 10 to 90% rH non-condensing
- electromagnetic vicinity: no nearby high frequency (HF) surgical equipment and no nearby shielded room of an MRI system

The **bili•hut™** is appropriate for use in hospital settings such as Neonatal Intensive Care Units (NICUs), Special Care Nurseries, Well-Baby Nurseries, Postpartum/Mothers' Rooms, and Emergency Rooms.



2.4 General Warnings

Warnings describe serious adverse reactions and potential safety hazards, limitations in use imposed by them, and steps that should be taken if they occur. General warnings are listed in this section. Specific warnings are listed with the relevant device use instructions.









2.4.1 Electrical Warnings

	Only use the power supply supplied by Little Sparrows Technologies. Using non-standard electrical parts may result in undertreatment or electrical shock of the patient.
	Only plug the bili•hut™ into a properly grounded electrical outlet. Plugging the bili•hut™ into an unsafe outlet could result in malfunction of the device or injury to the patient.







2.4.2 Environmental Warnings

	<p>DO NOT operate the bili•hut™ if any of the below are present:</p> <ul style="list-style-type: none"> • nitrous oxide • an oxygen-rich environment • a flammable anesthetic mixture of gases • flammable cleaning agents <p>Doing so could result in danger to the patient and/ or user.</p>
	<p>DO NOT operate the bili•hut™ in an environment where the intensity of electromagnetic (EM) disturbances is high (e.g. near high frequency (HF) surgical equipment and/or near a shielded room of an MRI system). Operating the bili•hut™ in this kind of environment may cause the performance of the bili•hut™ to degrade.</p>

2.4.2 Environmental Warnings (continued)

	<p>Portable RF communications equipment should be used no closer than 12 inches (30 cm) to any part of the bili•hut™. This includes peripherals such as antenna cables and external antennas. Use of such equipment could result in degraded performance of the bili•hut™.</p>
	<p>NEVER lay anything on top of the assembled bili•hut™ or any of its components. Doing so could result in damage to the structure of the bili•hut™ and/or injury to the patient.</p>
	<p>DO NOT block the front and rear openings of the bili•hut™ during treatment. Doing so could result in over-heating of both the patient and device as well as patient suffocation.</p>
	<p>DO NOT use or store the bili•hut™ in direct sunlight. Doing so could damage the device or result in over-heating of the patient.</p>
	<p>NEVER stack the assembled bili•hut™ on top of other equipment. Doing so could result in damage to the device. During treatment, this could result in injury to the patient.</p>
	<p>DO NOT use the bili•hut™ in a bassinet stand without the assembled perch. Doing so could result in injury to the patient.</p>
	<p>DO NOT transport the bili•hut™ with an infant inside. The bili•hut™ is not a “transporting” device. Doing so could result in injury to the infant.</p>
	<p>DO NOT store infusion liquids or pharmaceuticals near bili•hut™ as phototherapy lights may cause a photochemical reaction.</p>



2.4.3 Warnings About the Patient

	DO tend to other medical needs of the patient as needed. Determine safe sleeping positions for the patient if these needs require special attention.
	DO perform regular checks on the patient's bilirubin.
	NEVER carry the fully disposable nest, nest frame, or assembled bili•hut™ with the patient inside of it. Doing so could lead to patient injury.
	DO NOT treat the patient in the bili•hut™ if he or she has other medical conditions that require additional medical equipment. No medical equipment should be placed inside the bili•hut™ .
	The patient's water balance may be altered by phototherapy treatment. Regularly check the patient for diaper changes and change any wet diapers. Changing wet diapers prevents the patient from becoming too cold during treatment and helps monitor water balance.
	DO NOT place an infant in the perch without using the bili•hut™ in the perch . This could result in injury to the patient.
	Note that the reflective interior of the bili•hut™ shell is designed to increase patient exposure to the blue LED treatment lights; however, in certain environments, it may result in increased patient body temperatures. Regularly check on the patient and monitor the patient's body temperature to prevent over-heating.



2.5 General Cautions

Cautions draw your attention to any hazards that could damage the device or could result in severe but reversible injury to the patient and/or user. General cautions are listed in this section. Specific cautions are listed with the relevant device use instructions.





2.5.1 Electrical Cautions

	Disconnect the bili•hut™ from the power supply when the device is not in use and before cleaning.
	DO NOT move the bili•hut™ by pulling on the power cord. This could result in damage to the device.

2.5.2 Cautions About the Patient

 	Use and assemble this device only in the way described in this manual and only for the intended use as specified in Sections 1.2, 3.1, and 3.2 . Using the bili•hut™ for other purposes may be harmful to the patient and/or user.
--	--

2.5.3 User Cautions

 	The bili•hut™ flaps shield the area around it from the blue LED treatment lights so that only a small amount of blue light will be seen by the user. However, some people are very sensitive to blue light and, during prolonged exposure, may experience discomfort such as eye irritation, nausea, or headache. If the user or anyone else experiences this type of discomfort while near the bili•hut™ , discomfort will likely be resolved by wearing eye protection.
	Use only the instructions supplied with the bili•hut™ . Use of an unauthorized manual or other unauthorized instructional materials may lead to misuse and undesirable results.
	This manual is not a substitute for healthcare professional guidance.

Section 3: Using the bili-hut™

3.1 Assembling and Setting-up the bili-hut™

Complete the following six (6) steps to assemble and set-up the bili-hut™.

Unpacking:

- 1 Remove all components from their packaging.

Assembling the base:

- 2 If not already attached, pull the **base mattress** straps through the slots in the **base**. The red trim on the **base mattress** should face up and align with the side of the **base** with red straps. Secure the snaps.

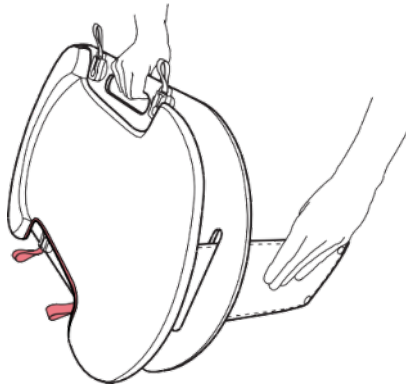

Assembling the hut:

- 3 Align the red-striped **shell** tab with the matching red straps on the **base**. Attach the magnetic clasps. The clasps will “click” and mechanically lock when in place.

Section 3: Using the bili-hut™

- 4 Holding the **base** by the handle, align the solid gray tab of the **shell** with the matching gray straps on the **base**. Attach the magnetic clasps. The clasps will “click” and mechanically lock when in place.

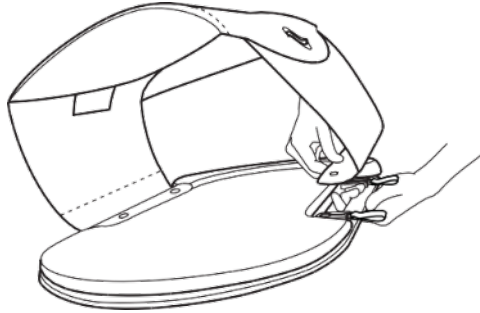

NOTE: Check for secure attachment by gently tugging upward on the **shell**. Look to see if all four clasps are still in place. If any of the four clasps are not in place, reference troubleshooting item #8 in **Section 5** of this manual.

WARNING







DO NOT place the **bili•hut™** near a:

- space heater
- radiator or heating vent
- other device that gives off heat or has a hot surface

Also DO NOT place the bili•hut™ in:

- direct sunlight
- extremely high room temperatures

Doing so could damage the device, lead to the patient becoming over-heated or cause burns or other patient injury, and/or lead to the Environment High Temperature Warning yellow indicator light to turn on.

<p>WARNING</p> 	<p>DO NOT place the bili•hut™ near cooling sources such as:</p> <ul style="list-style-type: none"> • fans • air conditioners or other devices that are cold or cool the air <p>Also DO NOT place the bili•hut™ in extremely low room temperatures. Doing so could lead to the patient becoming too cold. The Environment High Temperature Warning yellow indicator is NOT caused by cooling sources or low room temperatures.</p>
<p>WARNING</p> 	<p>DO NOT place the bili•hut™ on an uneven surface or a surface smaller than 2 x 4 feet (0.6 m x 1.2 m) without barriers. Doing so could result in injury to the patient.</p>
<p>WARNING</p> 	<p>DO NOT place the bili•hut™ near a source of liquid that could spill into or onto the device. Doing so could result in damage to the device and/or electrical shock of the user and/or patient.</p>
<p>CAUTION</p> 	<p>DO NOT place or store the bili•hut™ on or near an abrasive surface. Doing so could damage the device and/or its components.</p>

Placement of the assembled bili•hut™:

- 5 If using the **perch**:
- a. Unfold the **perch**.
 - b. Close all four snaps so that the gray walls are facing out.
 - c. Place the **perch** in a compatible hospital bassinet stand (see **Section 1.4.4** for assembled **perch** dimensions).
 - d. Place the **assembled bili•hut™** in the **perch**.

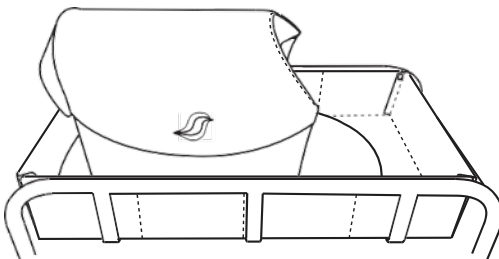

Section 3: Using the bili-hut™

OR if **NOT** using the **perch**:

Place the **assembled bili-hut™** on a smooth, sturdy, even surface, such as a table measuring at least 2 x 4 feet (0.6 m x 1.2 m).

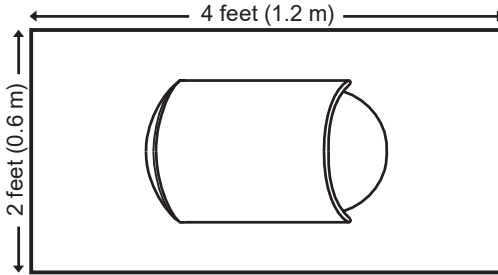

Alternatively, the **bili-hut™** can be used in a crib.

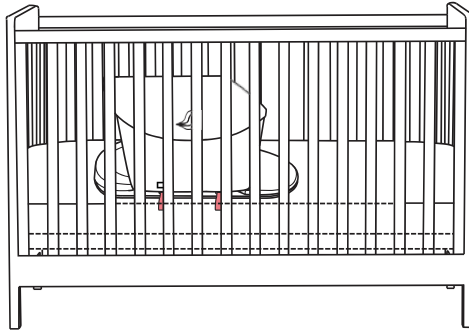

*Assembling the **power supply**:*



- 6 To assemble the **power supply**, connect the AC cord to the power brick.

3.2 Operating the bili•hut™

NOTE: Before starting treatment, complete the following steps:

1. Completely read and understand this manual.
2. Measure the irradiance of the **bili•hut™**. Measure irradiance using an irradiance meter placed in the center of the **fully disposable nest with fully disposable nest mattress** positioned in the **assembled bili•hut™**. Reference **Section 3.1** for instructions on how to prepare the **assembled bili•hut™**. Continue reading **Section 3.2** for instructions on **fully disposable nest alignment** and how to turn on the **bili•hut™**. The irradiance should measure at least 30 $\mu\text{W}/\text{cm}^2/\text{nm}$ with the wavelength centered around 460nm. If the irradiance measures below 30 $\mu\text{W}/\text{cm}^2/\text{nm}$, check for proper assembly using the appropriate components. Reference troubleshooting item #9 in **Section 5** of this manual if the issue persists.
3. Read the **bili•hut™ Clinical Record Sheet Instructions** in Appendix A.

NOTE: Fill out the top section of the **bili-hut™ Clinical Record Sheet**.

<p>WARNING</p> 	<p>DO NOT put any creams or lotions on the patient's skin before or during treatment. Doing so could change the effectiveness of the phototherapy, resulting in less treatment for the patient than desired.</p>
<p>CAUTION</p> 	<p>DO NOT place items in the assembled bili•hut™ or any nest configuration that could alter or lift the patient's position. Keeping the patient flat on either fully disposable nest mattress or disposable nest liner mattress provides the best possible treatment for the patient and prevents suffocation or over-heating of the patient.</p>

Section 3: Using the bili-hut™

NOTE: Blue light can hinder clinical observations by masking skin color changes, such as cyanosis.

Once the **assembled bili•hut™** is set up according to the instructions in **Section 3.1** and placed in an appropriate location, follow the next two (2) steps when using standard **fully disposable nest frame** and **fully disposable nest mattress**. If using **disposable nest liner, disposable nest liner mattress**, and **nest frame**, skip to step 3.

NOTE: If this manual refers to a “**nest**” component, it refers to either **fully disposable nest** or **nest frame** assembled as described in this section; depending on configuration used.

- 1 Place the **fully disposable nest mattress** in the **fully disposable nest frame** so that the dark section of the **fully disposable nest mattress** is facing up.

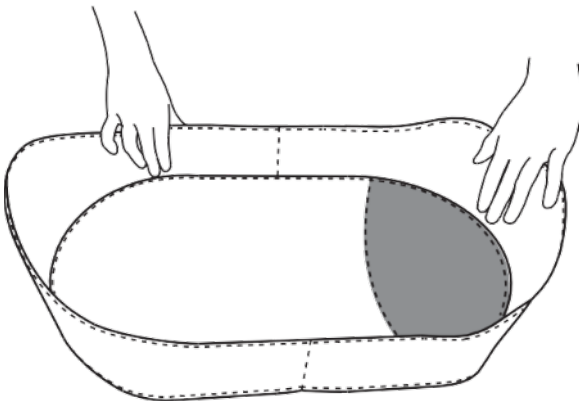

- 2 Place the **fully disposable nest frame** partially into the head-end of the **assembled bili•hut™**. The color block end of the **fully disposable nest frame** should remain outside of the **assembled bili•hut™**. Skip to step 6.

- 3 Line up the bottom opening of the **disposable nest liner** with the **nest frame**. Pull down on the **disposable nest liner** until it is lined up with the bottom edges of the **nest frame**.

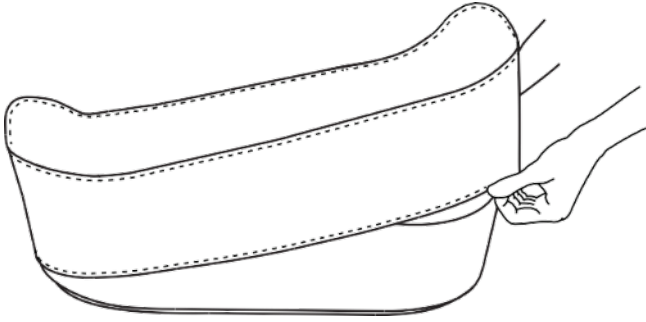

- 4 Place the **disposable nest liner mattress** in the **nest frame** so that the dark section of the **disposable nest liner mattress** is facing up.

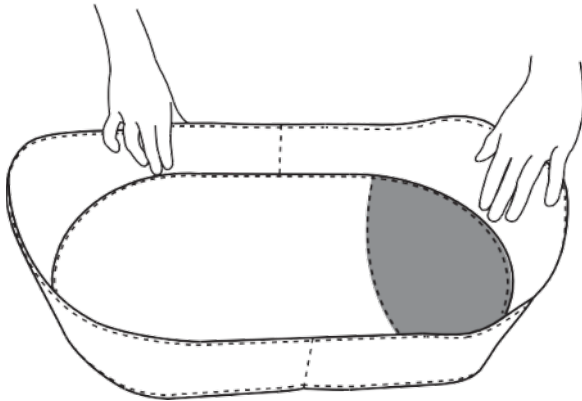



- 5 Place the **nest frame** partially into the head-end of the **assembled bili•hut™**. The color block end of the **disposable nest liner mattress** should remain outside of the **assembled bili•hut™**.

Section 3: Using the bili-hut™

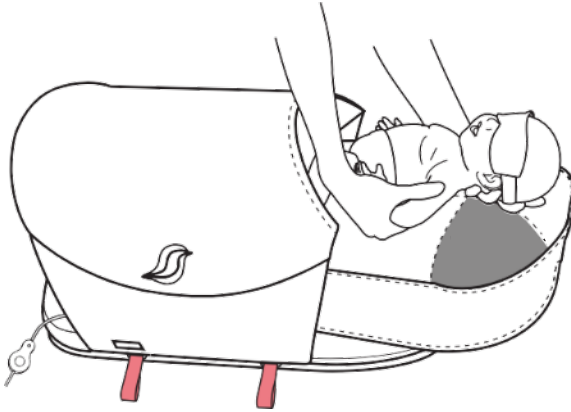
- 6 Undress the patient except for a diaper. Place eye protection over the patient's eyes. Then, place the diapered patient on the **nest mattress** on his or her back (supine position). The patient's head and neck should lie entirely within the dark section of the **nest mattress**.



<p>WARNING</p> 	<p>DO NOT operate the bili•hut™ before protecting the patient's eyes using eye protection. Treatment without eye protection could damage the patient's vision.</p>
<p>WARNING</p> 	<p>Only place a single diapered patient in the bili•hut™. Placing any other objects in the bili•hut™ could result in patient suffocation, over-heating, or other injury. It could also damage the bili•hut™.</p>
<p>WARNING</p> 	<p>NEVER place the patient in the assembled bili•hut™ without a nest component. Only use the bili•hut™ with a nest. Use of the bili•hut™ without a nest could lead to patient injury or undertreatment of the patient. Nest refers to either fully disposable nest or nest frame with disposable liner and mattress.</p>

- 7 Gently slide the **nest** into the **bili-hut™** until the **nest** touches the bumper at the foot-end of the **base mattress**. Ensure that the **shell** front flap is pushed down and inward and the **shell** back flap is pulled down and outward toward the foot-end of the **assembled bili-hut™**.

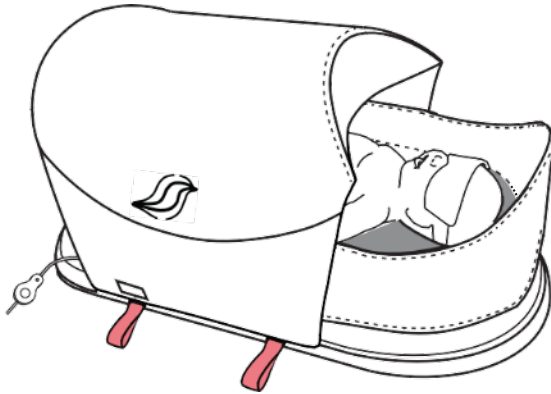

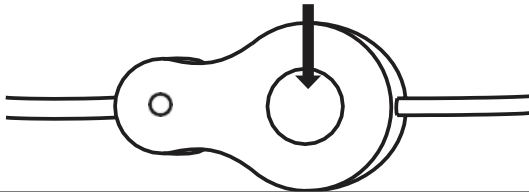

- 8 Plug the pronged end of the **power supply** into a safe and active electrical outlet. Plug the other end of the **power supply** into the barrel connector of the **bili-hut™** power cord. If using the **perch**, place the power brick in the mesh pouch. If not using the **perch**, route the **power supply** and cord in such a manner as to not interfere with the operation of the **bili-hut™**.
- 9 Press the power switch on the power cord to turn on the blue LED treatment lights.



NOTE: Complete the **bili-hut™ Clinical Record Sheet** for steps completed so far (ex. start of treatment).

3.3 Removing the Patient from the **bili•hut™**

<p>WARNING</p> 	<p>Phototherapy may alter the patient's body temperature. Therefore, check the following every 2 to 4 hours:</p> <ul style="list-style-type: none">• the patient's body temperature• the patient's diaper• ensure the patient's head and neck lie entirely within the dark section of the nest mattress• ensure the Environment High Temperature Warning yellow indicator light is NOT on
<p>CAUTION</p> 	<p>Phototherapy treatment should only be interrupted when needed for:</p> <ul style="list-style-type: none">• feeding• diaper changes• medical needs• end of treatment• an Environment High Temperature Warning• other necessary interruptions

Complete the following two (2) steps to remove the patient from the **bili•hut™**. Return the patient to the **bili•hut™** as soon as possible after an interruption.

- 1 Turn off the blue LED treatment lights before removing the patient from the **bili•hut™**. To turn off the blue LED treatment lights, press the power switch on the power cord.

- 2 Gently slide the **nest** out of the **assembled bili-hut™**. Carefully lift the patient out of the **nest** and place in a safe location. Remove the patient's eye protection.

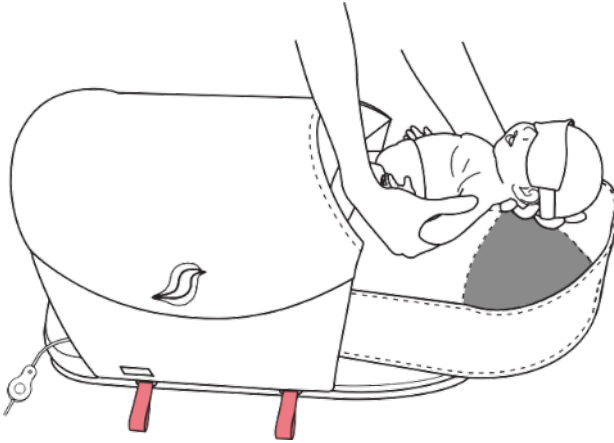

NOTE: Record any treatment interruptions using the **bili-hut™ Clinical Record Sheet**.

To resume treatment, follow the instructions starting at **Step 6** of **Section 3.2** of this manual.

WARNING



Avoid interrupting treatment unless necessary. Resume therapy as soon as possible after the interruption. If treatment is interrupted for a long period or is interrupted too frequently, it could reduce the effectiveness of the treatment.

3.4 Actions for an Environment High Temperature Warning

The Environment High Temperature Warning automatically turns on when the environment temperature surrounding the **bili•hut™** is too high. During the Environment High Temperature Warning, the blue LED treatment lights turn off and a yellow indicator light turns on.

The Environment High Temperature Warning may occur if the **bili•hut™** is used near:

- radiators
- heating vents
- space heaters
- other heat sources

OR if the **bili•hut™** is used in:

- direct sunlight
- extremely high room temperatures

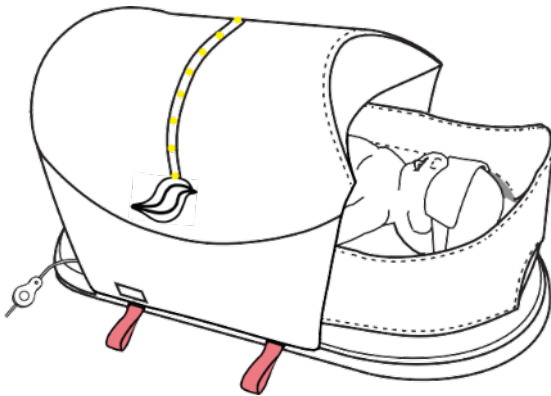

When the environment temperature lowers to a safe range, the yellow indicator light will turn off. At that time, the blue LED treatment lights will automatically turn back on.

Follow the flowchart instructions starting at the top of the next page when the Environment High Temperature Warning occurs. This warning is visible when the yellow indicator light turns on and the blue LED treatment lights turn off.

NOTE: Record interruptions to treatment on the **bili-hut™ Clinical Record Sheet** when the Environment High Temperature Warning occurs.

Environment High Temperature Warning turns on.

REMOVE THE PATIENT:

- 1.** DO NOT turn off the **bili-hut™**.
- 2.** Gently slide the **nest** out of the **assembled bili•hut™**.
- 3.** Carefully lift the patient out of the **nest** and place in a safe location. Remove the patient's eye protection.

TROUBLESHOOT:

First:

- Turn off and/or move any heat sources such as radiators, heating vents, or space heaters. Relocate the **bili-hut™** away from heat sources if necessary.

In addition, the user can:

- Ensure the **bili-hut™** is not in direct sunlight.
- Lower the ambient temperature of the room.
- Move the **bili-hut™** to a cooler, safe location.

Wait for the blue LED treatment lights to turn back on. This may take a few minutes. The **bili-hut™** must be left on during this time to see when the Environment High Temperature Warning automatically turns off.

If the blue LED treatment lights remain off for >1 hour and the user completed all possible troubleshooting items as listed above, call Little Sparrows Technologies using the contact information in **Section 6**.

The yellow indicator light turns off and the blue LED treatment lights turn back on.

RESUME TREATMENT:

Place eye protection over the patient's eyes. Place the patient in the **nest** and gently slide the **nest** into the **assembled bili•hut™** until the **nest** touches the bumper at the foot-end of the **base mattress**.

3.5 Disassembly

WARNING



DO NOT disassemble the **bili•hut™** while a patient is inside. Doing so may lead to patient injury.

NOTE: Record the end of treatment on the **bili-hut™ Clinical Record Sheet**.

Disassemble the **bili•hut™** using the following eight (8) steps when treatment is complete.

- 1 Follow the instructions to remove the patient from the **bili•hut™** in **Section 3.3**.
- 2 Unplug the **bili•hut™** from the electrical outlet and disconnect the **power supply** from the **bili•hut™** power cord.
- 3 Completely remove the used **nest configuration** from the **assembled bili•hut™**.
- 4 If using the **fully disposable nest** configuration, dispose of the **nest** and **mattress** in a general waste bin or according to institutional policy.

If using the **nest frame** configuration, Lift the **disposable nest liner mattress** out of the **nest frame**. Remove the **disposable nest liner** from the **nest frame**. Dispose of the **disposable nest liner mattress**, and **disposable nest liner** in a general waste bin or according to institutional policy.

NOTE: Please see the contact information in **Section 6** of this manual to reorder **fully disposable nests**, **fully disposable nest mattresses**, **disposable nest liner mattresses**, and **disposable nest liners**.

- 5 Pull the red straps outward from the **assembled bili-hut™** to release the magnetic clasps. Repeat this step with the gray straps on the other side of the **shell** to release the **shell** from the **base**.

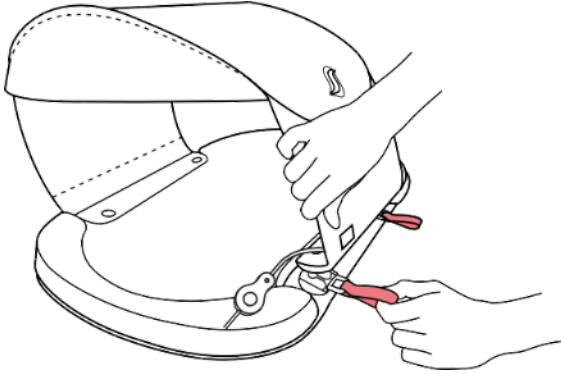

- 6 If applicable, undo the four snaps on the **perch** and remove from the bassinet stand.
- 7 Clean the **shell, base, base mattress, perch,** and **nest frame** (if using nest frame configuration) according to the instructions in **Section 4.1** of this manual.

CAUTION







DO NOT store the **bili-hut™** near open water such as a tub or sink where it could fall in. Doing so could damage the device and/or its components.

- 8 Store the **bili-hut™** components until their next use.

Section 4: Maintenance

<p>WARNING</p> 	<p>DO NOT perform service or maintenance on the bili•hut™ or any of its components during use. Doing so could result in injury or electric shock to the user or the patient.</p>
--	---

4.1 Cleaning

<p>WARNING</p> 	<p>DO NOT use flammable cleaning agents when cleaning the device. DO NOT use cleaning agents containing ethanol or hydrogen peroxide, abrasive cleaning agents, or abrasive cleaning tools to clean the bili•hut™ because these may damage the device. Only use the cleaning agents and tools specified in Section 4.1 to clean the bili•hut™.</p>
<p>WARNING</p> 	<p>DO NOT use a soiled bili•hut™. Failure to complete the cleaning described in Section 4.1 could lead to undertreatment, skin irritation, and/or infection of the patient.</p>
<p>CAUTION</p> 	<p>Disconnect the bili•hut™ from the power supply when the device is not in use and before cleaning.</p>
<p>CAUTION</p> 	<p>DO NOT immerse any bili•hut™ components in liquid such as water or cleaning solutions. DO NOT spray water, cleaning agents, or any other liquid directly on the bili•hut™. DO NOT clean the bili•hut™ using an over-saturated wipe/cloth. Any of these actions may damage the efficiency and integrity of the device.</p>

Acceptable cleaning methods:

Use a hospital-grade cleaning agent with one of the following active ingredients:

- quaternary ammonium OR
- bleach

DO NOT use cleaning agents containing ethanol or hydrogen peroxide, abrasive cleaning agents, or abrasive cleaning tools to clean the **bili•hut™** as these may damage the device.

Follow the instructions provided by the manufacturer of the cleaning agent including any instructions which recommend wiping the device with water before/after cleaning.

Clean the **bili•hut™** components as outlined in this Section by using a wipe/cloth that has been:

- sprayed with cleaning agent OR
- dampened with cleaning agent OR
- pre-dampened with cleaning agent by the manufacturer

*When to clean the **bili•hut™**:*

If any component(s) become soiled during use, stop treatment using the instructions in **Section 3.3**. Replace a soiled **disposable** component with a new one. If a reusable portion of the **bili•hut™** (**nest frame, shell, base mattress, base, or perch**) also becomes soiled during use, clean the soiled component(s) using the following instructions, and then resume treatment.

Clean all reusable components according to the following instructions between use with each patient and before and after servicing the **bili•hut™**.

Dispose of the **nest mattress** between patients.

DO NOT resume treatment or pack up the device into its carrier until all components are clean and dry.

4.1.1 Cleaning the **nest frame**

Wipe down the uncovered **nest frame**. Visually inspect the **nest frame** and repeat the cleaning process if the **nest frame** still appears dirty. Allow to air dry.

4.1.2 Cleaning the **shell**

Clean the interior of the **shell** by wiping down the light array and reflective material. Allow to air dry.

If dirtied, wipe down the exterior of the **shell**. DO NOT use excess cleaning agent. Allow to air dry.

4.1.3 Cleaning the **base** and **base mattress**

To clean the **base mattress**, undo the snaps and remove from the **base**. Wipe down the **base** and **base mattress**. Allow to air dry.

Once dry, reattach the **base** and **base mattress**.

4.1.4 Cleaning the perch

Wipe down all panels of the disassembled **perch**. Allow to air dry.

Once dry, the **perch** can be folded for storage (as shown below) or re-assembled according to the instructions in **Section 3.1** for the next use.

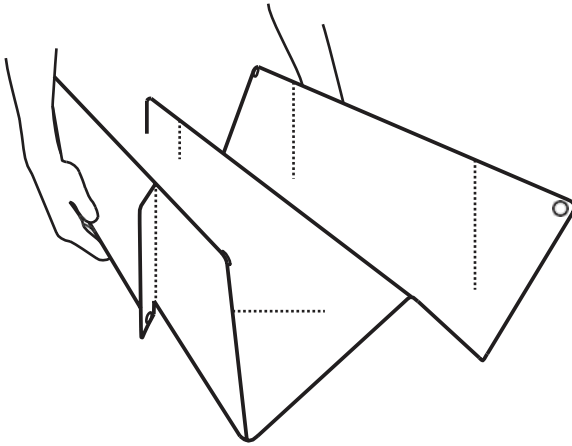

4.2 Disposal

Dispose of the **fully disposable nest configuration or disposable nest liner and disposable nest liner mattress** when soiled *and* at the end of treatment.

Dispose of the **disposable nest liner mattress** at the end of treatment.

To dispose of a soiled **disposable nest liner mattress**, disposable **nest liner**, **fully disposable nest** configuration place the item in a general waste bin or otherwise dispose of according to institutional policy.

Please see the contact information in **Section 6** of this manual to order additional **fully disposable nest** sets, **disposable nest liner mattresses**, and **disposable nest liners**.

Section 4: Maintenance

The **bili•hut™ shell** (with treatment lights), **power supply**, and **power cord** are electronic equipment. DO NOT dispose of these components as unsorted waste. Deliver them to a suitable collection point for recycling of electronic equipment in accordance with local regulations and institutional policies.

For questions regarding the disposal of any other of the **bili•hut™**'s components, contact Little Sparrows Technologies. For contact information, see **Section 6** of this manual.

Section 5: Troubleshooting

The following are a list of problems that may occur while using the **bili•hut™**.

DO NOT attempt to service the **bili•hut™** or its components beyond the instructions given in the following troubleshooting scenarios. If these steps below do not solve the problem, contact a Little Sparrows Technologies representative for assistance using the contact information in **Section 6**.

#	Problem	Action
1	The Environment High Temperature Warning remains on after following the troubleshooting instructions in Section 3.4 .	Contact Little Sparrows Technologies for assistance.
2	The patient is too cold.	<ol style="list-style-type: none"> 1. Remove the patient from the bili•hut™ and warm the patient, ideally using skin-to-skin care. 2. If possible, adjust the ambient temperature of the room or move the bili•hut™ to a warmer area. NEVER place the bili•hut™ under a radiant warming source or use it with a space heater or other heat-emitting device.
3	The patient is too warm.	<ol style="list-style-type: none"> 1. If the Environment High Temperature Warning is on, refer to Section 3.4. 2. Otherwise, remove the patient and take his or her body temperature again. Monitor patient temperature for a fever.

Section 5: Troubleshooting

#	Problem	Action
4	Liquid is spilled in or on the bili•hut™ .	<ol style="list-style-type: none"> 1. If in use, immediately press the power switch to turn off the bili•hut™. Then unplug the power supply from the electrical outlet. Remove the patient according to the instructions in Section 3.3. 2. Dry the bili•hut™ and replace any wet nest mattress components, disposable nest liner, or fully disposable nest. 3. If the bili•hut™ turns back on and operates normally, resume treatment. If not, DO NOT use. Contact Little Sparrows Technologies for assistance.
5	The bili•hut™ is not turning on or the light array is not emitting light.	<ol style="list-style-type: none"> 1. Check to see if the Environment High Temperature Warning yellow indicator is on. If it is on, follow the instructions in Section 3.4. 2. Ensure the power supply is properly assembled (AC cord is fully plugged in to the power brick). Ensure the power supply is properly connected to a safe and active outlet and the bili•hut™ power cord. 3. Ensure the power switch on the power cord is in the “ON” position and nothing is pressing on the power switch. 4. If the issue persists, DO NOT use. Contact Little Sparrows Technologies for assistance.

#	Problem	Action
6	Power cord or power supply appears frayed or is deteriorating.	DO NOT use. Contact Little Sparrows Technologies for assistance.
7	The bili•hut™ appears distorted or deformed when compared to the pictures of the device in this manual.	DO NOT use. Contact Little Sparrows Technologies for assistance.
8	One or more magnetic clasps on the shell is not clicking into place on the base or becomes undone after attachment.	Remove any debris from the magnetic clasps on the base and re-attach the magnetic clasp. The clasp will “click” and mechanically lock when in place. Check for secure attachment by gently tugging upward on the shell .

Section 5: Troubleshooting

#	Problem	Action
9	Irradiance measurement of blue LED treatment lights is below 30 $\mu\text{W}/\text{cm}^2/\text{nm}$.	<ol style="list-style-type: none"> 1. Ensure the measurement is obtained by following the instructions in Section 3.2. 2. Ensure the irradiance meter is functioning properly. 3. If dirtied, clean the light array according to the instructions in Section 4.1.3. 4. If the issue persists, contact Little Sparrows Technologies for assistance.
10	Blue LED treatment lights flicker or substantially increase/decrease in brightness.	<ol style="list-style-type: none"> 1. Remove bili•hut™ from sources of electromagnetic disturbances. 2. Ensure only the power supply supplied by Little Sparrows Technologies for use with the bili•hut™ is used. 3. Ensure the power supply is properly assembled (AC cord is fully plugged in to the power brick). Ensure the power supply is properly connected to a safe and active outlet and the bili•hut™ power cord. 4. Ensure that nothing is pressing on the power switch. 5. If device has been exposed to excess moisture, power off and follow steps outlined in Problem 4. 6. If the issue persists, DO NOT use. Contact Little Sparrows Technologies for assistance.

IMPORTANT: If troubleshooting reveals a health problem with the patient rather than an issue with the **bili•hut™**, determine the proper treatment path for the patient's health problem.

Section 6: Contact and Reorder Information

Contact a Little Sparrows Technologies representative if:

- taking the troubleshooting steps listed in **Section 5** does not resolve the associated problem
- more information is needed for operation or repair of the device
- you have any other comments or questions
- you need to reorder **fully disposable nests, fully disposable nest mattresses, disposable nest liners, or disposable nest liner mattresses**

fully disposable nest package	0133AFD
disposable nest liner package	0133ADL

Other products sold by Little Sparrows Technologies:

sparrow swaddle	0301A
------------------------	--------------

For a complete list of Little Sparrows Technologies products, please visit our website: www.littlesparrowstech.com.

To contact Little Sparrows Technologies:

Phone: (781) 725-2460

Email: info@littlesparrowstech.com

Mailing address:

Little Sparrows Technologies, Inc.

70 Tower Office Park



Woburn, MA 01801

(781) 725-2460

Twitter: [@TechSparrows](https://twitter.com/TechSparrows)

Facebook: Little Sparrows Technologies

Section 7: Specifications

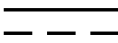
	IEC Type BF applied part
IP23	IP23
	IEC Class II equipment
	FDA Class II
	Direct Current

Component	PN or REF
base	0106C
base mattress	0109H
perch	0108A
nest frame	0103B
disposable nest liner package	0133ADL
fully disposable nest package	0133AFD
power supply	0116CPS
power cord	0116CUS
shell	0102D

7.1 Electrical

Power Consumption	20 Watts
LED Module Estimated Life	Up to 50,000 hours
Timer Display	Range: 99,999.9 Hours
Size of Light Source	16 x 6 inches (40.6 x 15.2 cm)
bili•hut™ Fuses	3.0A 32Vdc and 2.5A 40Vdc on DC input
Power Supply Fuses	2.0A 250Vac on Line and 2.0A 250Vac on Neutral
Degree of Protection Against Electrical Shock	2x MOPP
Cable Length	10 inches (25.4 cm)
Power Supply: Input	120-230VAC, 50/60Hz, 1.2A, Class II
Power Supply: Output	12VDC, 3.4A

7.2 shell

Dimensions (flat)	34 x 17 inches (86.5 x 43 cm)
Materials	Nylon, thermoplastic polyurethane (TPU), mylar, polycarbonate, foam
Service Life	Up to 3 years of use if used with care and within the ranges recommended in this document

7.3 base

Dimensions	24.5 x 14 inches (62 x 35.5 cm)
Materials	High-density polyethylene (HDPE), nylon, aluminum, rubber, steel
Service Life	Up to 3 years of use if used with care and within the ranges recommended in this document

7.4 base mattress

Dimensions	24.5 x 14 inches (62 x 35.5 cm)
Materials	Vinyl, foam, nylon, metal, polyester, cotton
Service Life	Up to 1 year of continuous use if used with care and within the ranges recommended in this document

7.5 nest

Dimensions	22.5 x 13 x 7 inches (57 x 33 x 18 cm)
Materials	TPU
Service Life	Up to 3 years of continuous use if used with care and within the ranges recommended in this document

7.6 Fully disposable nest mattress

Dimensions	21 x 11 inches (56 x 32 cm)
Materials	Polyurethane, polyester, foam
Service Life	Single use disposable

7.7 Fully disposable nest

Dimensions	24.25 x 14 x 1 inches
Materials	Polyurethane, polyester
Service Life	Single use disposable

7.8 disposable nest mattress

Dimensions	22 x 12.5 inches (56 x 32 cm)
Materials	Polyurethane, polyester
Service Life	Single use disposable

7.9 disposable nest liner

Dimensions	21 x 12 x 1 inches
Materials	Polyurethane, polyester
Service Life	Single use disposable

7.10 perch

Dimensions	(assembled) 28.5 x 15 x 5.5 inches (72.5 x 38 x 13.5 cm)
Materials	Nylon, polyester, HDPE, nickel-plated metal
Service Life	Up to 1 year of continuous use if used with care and within the ranges recommended in this document

7.11 bili•hut™ (assembled)

Dimensions	25 x 16 x 12 inches (63.5 x 40.5 x 30.5 cm)
Weight	8 lbs (3.5 kg)
Estimated Device Lifetime	Up to 3 years of use if used with care and within the ranges recommended in this document
Maximum Noise Level	0.5 dB
Treatment Distance	8.3 inches (21 cm)

7.12 Environmental

Storage Temperature	-40°F to +158°F (-40°C to +70°C)
Storage Humidity	10 to 90% rH non-condensing
Storage Altitude	10,000 feet (3000 m) maximum
Operating Temperature* (range over which the bili•hut™ meets all performance specifications)	41°F—104°F (5°C—40°C)
Operating Humidity	10 to 90% rH non-condensing
Operating Altitude	10,000 feet (3000 m) maximum
Operating Electromagnetic Environment	Not to be used around high-intensity EM disturbances (e.g. HF equipment, near a shielded room of an MRI system).
Internal Temperature of the bili•hut™ that triggers the Environment High Temperature Warning	≤109.4°F (≤43°C) (in accordance with IEC 60601-2-50)
Ingress Protection	IP23 protects against solid objects over 12 mm and sprays of water from any angle up to 60° from the vertical

***NOTE:** The recommended room temperature range for treatment with the **bili•hut™** is 70°F—76°F (21.1°C—24.4°C). For more information on recommendations for safe treatment, see **Section 2.3** of this manual. Phototherapy with the **bili•hut™** may alter the patient's body temperature.

7.13 WEEE Statement

Little Sparrows Technologies is committed to meeting the requirements of the European Union WEEE (Waste Electrical and Electronic Equipment) Regulations 2014. These regulations state that electrical and electronic waste must be separately collected for the proper treatment and recovery to ensure that WEEE is reused or recycled safely. In line with that commitment Little Sparrows Technologies may pass along the obligation for take back and recycling to the end user, unless other arrangements have been made. Please contact us for details on the collection and recovery systems available to you in your region.

Electrical and electronic equipment (EEE) contains materials, components and substances that may be hazardous and present a risk to human health and the environment when WEEE is not handled correctly. Therefore, end users also have a role to play in ensuring that WEEE is reused and recycled safely. Users of electrical and electronic equipment must not discard WEEE together with other wastes. Users must use the municipal collection schemes or the producer/importers take-back obligation or licensed waste carriers to reduce adverse environmental impacts in connection with disposal of waste electrical and electronic equipment and to increase opportunities for reuse, recycling and recovery of waste electrical and electronic equipment.

Equipment marked with the crossed-out wheeled bin (WEEE symbol above) is electrical and electronic equipment. The crossed-out wheeled bin symbol indicates that waste electrical and electronic equipment should not be discarded together with unseparated waste but must be collected separately.

7.14 Spectral Irradiance

7.14.1 Wavelength

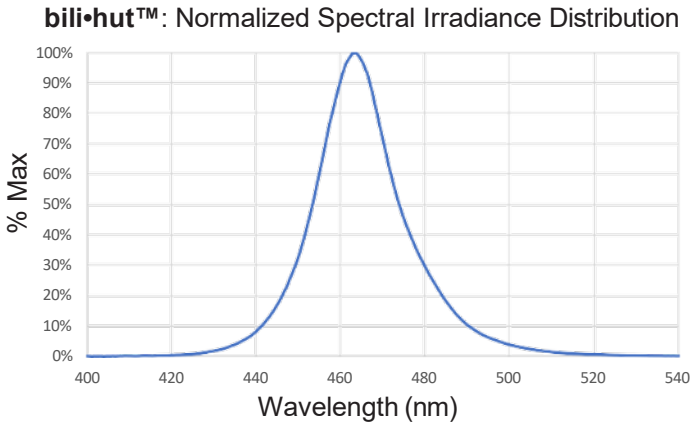

Light Source output: 430nm – 490nm

Peak Irradiance: 450nm – 470nm

7.14.2 Irradiance Map of **fully disposable** configuration

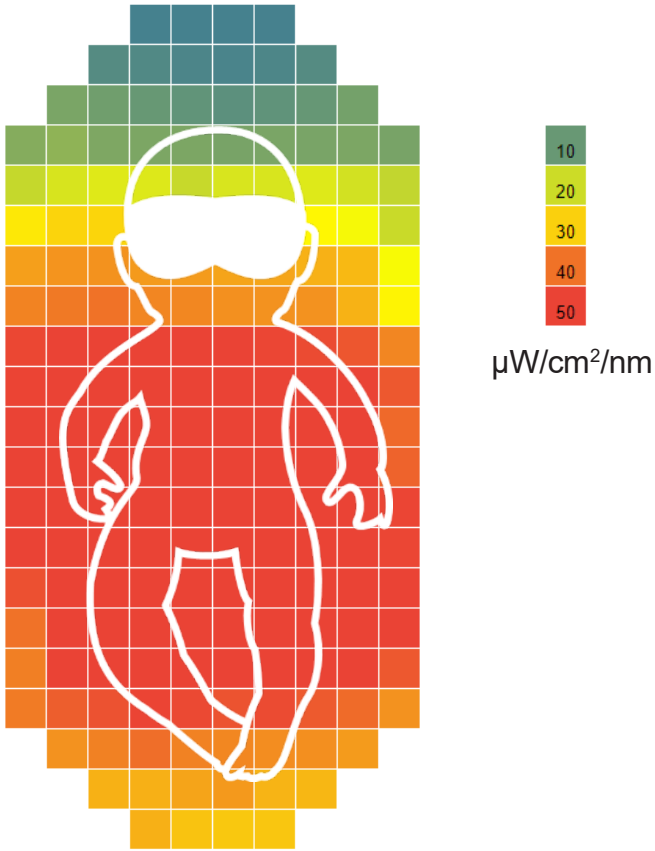

Measured at a distance of 21 cm from the blue LED treatment lights

Total Treatment Area	186 in ² (1200 cm ²)
Effective Treatment Area	138 in ² (890 cm ²)
E _{bi} max	56.3 [52.7-59.9] $\mu\text{W}/\text{cm}^2/\text{nm}$
Average Irradiance within Effective Treatment Area	46.6 [43.1-50.2] $\mu\text{W}/\text{cm}^2/\text{nm}$

7.14.3 Irradiance Map of **disposable nest liner** configuration

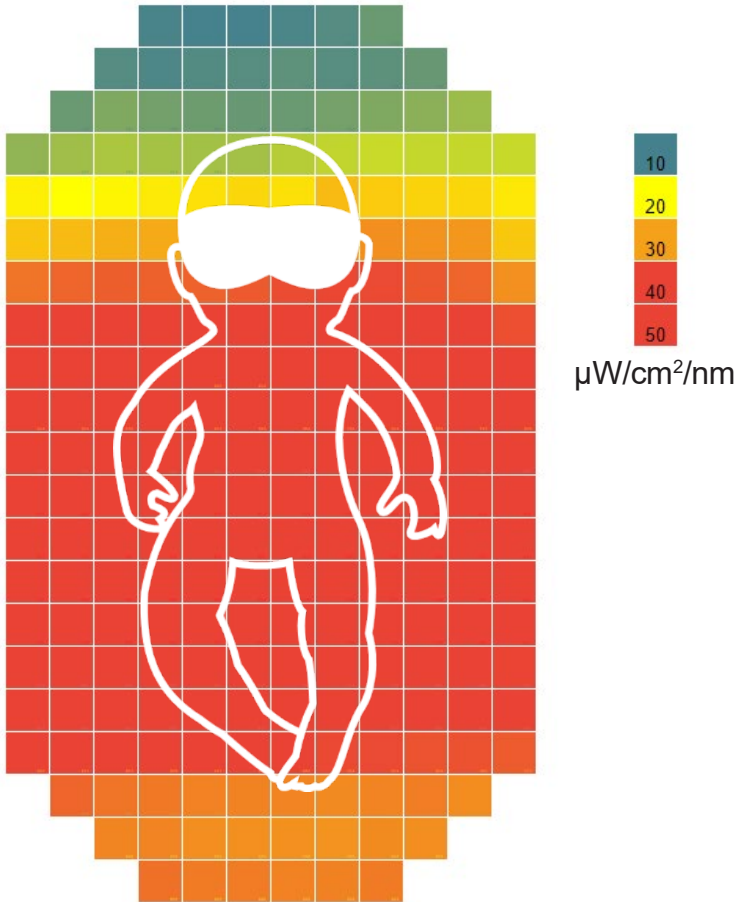

Measured at a distance of 21 cm from the blue LED treatment lights

Total Treatment Area	228 in ² (1471 cm ²)
Effective Treatment Area	156 in ² (1006 cm ²)
$E_{\text{bi max}}$	56.3 [52.7-59.9] $\mu\text{W}/\text{cm}^2/\text{nm}$
Average Irradiance within Effective Treatment Area	46.6 [43.1-50.2] $\mu\text{W}/\text{cm}^2/\text{nm}$

7.14.4 Spectral Sensitivity of the Irradiance Measurement Device

The following graph shows the nominal response characteristics of the GE BiliBlanket Light Meter II, which corresponds to the peak absorption spectrum of bilirubin. The irradiance of every **bili•hut™** device is measured with the BiliBlanket Light Meter II or equivalent at the manufacturer prior to shipment.

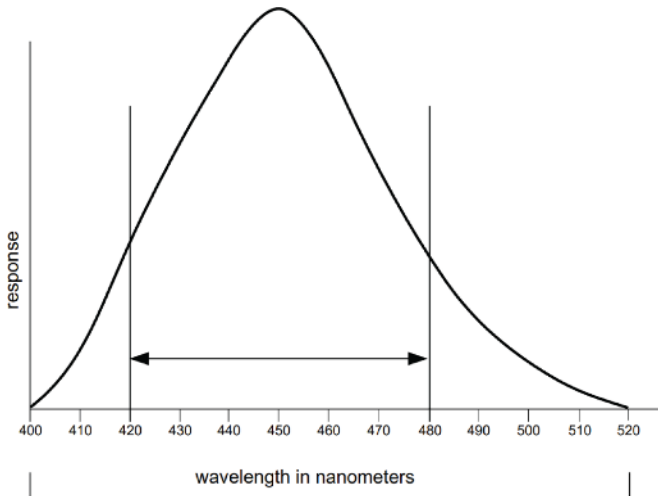

Appendix A

Clinical Record Sheet Instructions

While the patient receives phototherapy from the **bili-hut™**, it is important to record information about the patient's treatment as outlined below.

Treatment records may influence treatment decisions for the patient and supplement records for the patient's physician. Use a new **Clinical Record Sheet** for each day of treatment.

Top Section: At the start of each treatment day, fill out the **top section** of the record sheet: **Date**, **Patient's ID**, **Birth Weight** (in lbs/oz or kg on the appropriate line), **Date of Birth**, and **Time of Birth** (circle am or pm).

1st Column (Start/Resume Time): When the patient begins receiving treatment from the illuminated **bili-hut™** (the power switch is turned on after the patient is properly positioned within the **bili-hut™**), record the start time in the first column of the first row of the sheet (circle am or pm).

8th Column (Clinical Staff Initials): Also when the patient begins receiving treatment from the illuminated **bili-hut™**, initial the row.

Each time an interruption occurs, complete the following columns of the next available row:

2nd Column (Time Removed from bili-hut™): Record the time you removed the patient from the **bili-hut™** (circle am or pm).

3rd Column (Armpit Temp): Record the patient's armpit temperature. Check the box at the top of the column for Celsius or Fahrenheit.

8th Column (Clinical Staff Initials): Initial the row.

Also fill out one or more of the following columns (if relevant to the interruption):

4th Column (Feeding): If you removed the patient for feeding, record either a bottle amount (circle either oz or ml) or the amount of time spent breastfeeding (min). Check the box corresponding to which type of feeding was done.

5th Column (Diaper Change): If you removed the patient for a diaper change, record whether the diaper had urine and/or stool in it by checking the appropriate box(es) in that column.

6th Column (EHTW): If you removed the patient for an Environment High Temperature Warning (EHTW) of the **bili-hut™**, check the "EHTW" box.

7th Column (Other — Specify): Record any other reason for removing the patient (interrupting treatment) by checking the "Other" box and specifying the reason.

When placing the patient back in the **bili-hut™**, complete the following column of the next row:

1st Column (Start/Resume Time): Record the time the treatment is resumed (circle am or pm).

8th Column (Clinical Staff Initials): Initial the row.

Upon completion of treatment, complete the following columns:

2nd Column (Time Removed from bili-hut™): Record the time you removed the patient from the **bili-hut™** (circle am or pm).

7th Column (Other — Specify): Note the end of treatment (EoT).

8th Column (Clinical Staff Initials): Initial the row.

Save the completed sheet.

Index

A

assembled bili-hut™ 2, 7, 18, 19, 23-29, 31, 33-35

B

base 2, 4, 5, 7, 21, 22, 29, 35, 37, 38, 43, 46, 48

base mattress 2, 4, 5, 21, 29, 35, 37, 38, 46, 48

bili-hut™ components, list of 2-10

Birthweight 16

Bumper 5, 29, 33,

C

Cautions *inner cover*, *iii*, 1, 20

Cleaning 17, 20, 36-39

Contact Information, LST 45

Contraindications 16

D

Disassembly 4, 15, 34-35

Disposable components 39

(Fully) disposable nest 3, 8,

19, 25, 26, 28, 34, 39, 42, 45, 49

(Fully) disposable nest

mattress 3, 9, 25, 26, 28, 34, 39, 45, 49

Disposable nest liner 11, 13, 26, 27, 34, 39, 42, 45, 46, 49

Disposable nest liner

mattress 11, 14, 25-27, 34, 39, 45, 46

Reorder information 45

Disposal 39, 40

E

Environment High Temperature

Warning 7, 22, 23, 30, 32, 33, 41, 42, 51

Eye protection *iii*, 20, 28, 31

G

Gestational Age 16

H

Handle 4, 22

Hyperbilirubinemia 1, 16

I

Indications for Use 16

Intended Use 1, 20

Interruptions 30, 31, 33

Irradiance 25, 44, 53-55

Map 54, 55

Measuring 25, 44, 53, 56

M

Magnetic clasps 4, 7, 16, 17, 21, 22, 35, 43, 44

N

Nest frame 8, 11-13, 19, 26-28, 34, 35, 37, 38, 46, 48

P

perch 2, 15, 18, 19, 23, 24, 29, 35, 37, 39, 46, 49

power supply 2, 7, 10, 15, 17, 20, 24, 29, 34, 36, 40, 42, 44, 46, 47

Product Responsibility *i*

R

Recommendations 16, 51

Record Sheet 25, 29, 31, 33, 34, 57, 58

Removing the Patient 30

S

Setting-up the **bili-hut™** 21

shell 2, 4, 6, 7, 10, 19, 21, 22, 29, 35, 37, 38, 40, 43, 46, 48

Snaps 4, 5, 21, 22, 35, 38

Specifications 46-56

Straps 4, 5, 21, 22, 35

Symbols *iii*

T

Table of Contents *ii*

Temperature Warning, Environment High *see Environment High*

Temperature Warning

Troubleshooting 22, 25, 33, 41-44

W

Warnings *iii*, 1, 7, 17-19, 22, 23, 25, 28, 30-34, 36, 41, 42, 51

WEEE *iii*, 52